

Evaluation Report

CCMC 13314-R

MASTERFORMAT

Issued

Re-evaluation due

06 18 13.03

2008-05-01

2011-05-01

Quattro™ Post

1. Opinion

It is the opinion of the Canadian Construction Materials Centre (CCMC) that “Quattro™ Post,” when used as glued-laminated timber columns in accordance with the conditions and limitations stated in Section 3 of this Report, complies with the National Building Code of Canada (NBC) 2005:

- Clause 1.2.1.1.(1)(b), Division A, as an alternative solution that achieves at least the minimum level of performance required by Division B in the areas defined by the objectives and functional statements attributed to the following applicable acceptable solutions:
 - Article 9.17.4.2., and
 - Sentence 4.3.1.1.(1).

This opinion is based on CCMC’s evaluation of the technical evidence in Section 4.1 provided by the Report holder.

2. Description

“Quattro™ Post” is manufactured by laminating graded kiln-dried, spruce-pine-fir (S-P-F) select structural, S-P-F No. 2 Douglas fir (DF) select structural, DF No. 2 lumber, or western red cedar. The columns are processed with a patented profile and then laminated together at right angles in custom-built presses to create a hollow core 89x89 (4” x 4”), 140x140 (6” x 6”) or 184x184 (8” x 8”) column. Once the pressing is complete, the columns are finished planed and trimmed to length.

The exterior grade phenol-resorcinol adhesive complies with CSA O112.7-M1977, “Phenol and Phenol Resorcinol Resin Adhesives for Wood (Room- and Intermediate-Temperature Curing).”

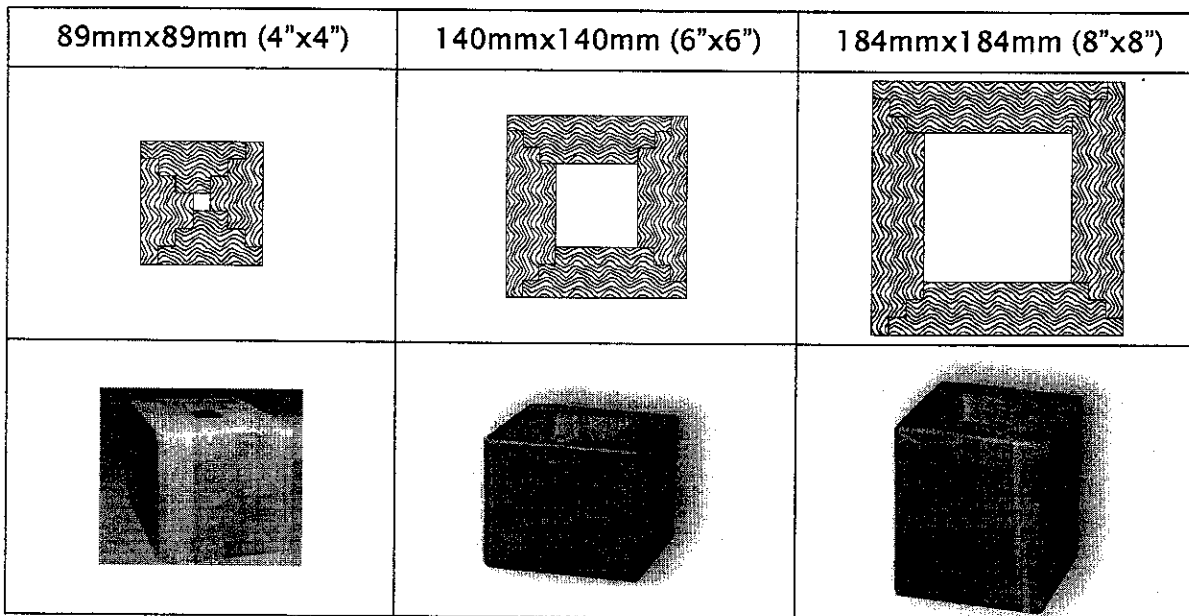

Figure 1. Product details for “Quattro™Post.”

3. Conditions and Limitations

CCMC’s compliance opinion in Section 1 is bound by the “Quattro™Post” being used in accordance with the conditions and limitations set out below.

The scope of this CCMC evaluation is limited to the “Quattro™Post” for dry service applications only⁽¹⁾. When the “Quattro™Post” is considered for wet service applications, a professional engineer with an expertise in wood science shall determine, in consultation with the manufacturer, the appropriate proprietary strength adjustment factor for the specific application.

“Quattro™Post” is intended for use in construction as an alternative to a solid sawn lumber column. Proprietary design values are presented for “Quattro™Post” to be designed by professional engineers in accordance with CAN/CSA-O86-01, “Engineering Design in Wood,” for structural applications in dry service conditions.

(1) All lumber, wood-based panels and proprietary engineered wood products are intended for “dry service conditions.” “Dry service” is defined as the in-service environment under which the equilibrium moisture content (MC) of lumber is 15% or less over a year and does not exceed 19% at any time. Wood contained within the interior of dry, heated or unheated buildings has generally been found to have a MC between 6% and 14% according to season and location. During construction, all wood-based products should be protected from the weather to ensure that the 19% MC is not exceeded in accordance with the NBC 2005, Division B, Article 9.3.2.5.

The pre-engineered tables in the literature outlined below have been provided to CCMC by Synergy Pacific to demonstrate compliance to Part 9 buildings for acceptance by the local authority having jurisdiction (AHJ):

i) “Quattro™Post’s” Pre-engineered Tables⁽²⁾

When “Quattro™Post” is used, the installation shall be in accordance with the content of the Synergy Pacific’s publication entitled “Quattro™ Post Handling and Installation Instructions,” dated 08-03-30.

“Quattro™Post” shall be installed in accordance with Synergy Pacific’s installation guidelines noted in these documents for those applications falling within the scope of the documents. Applications outside the scope of these installation guidelines shall require engineering on a case-by-case basis.

(2) *The pre-engineered Tables present the pre-engineered factored resistance of the column. The AHJ may require further engineering to determine the factored load applied onto the column in the building, in accordance with the NBC 2005, Division B, Part 4.*

ii) “Quattro™Post’s” Installation Details

- “Quattro™Post” bases, column caps and fasteners are required when the column has been designed for the intended use.
- “Quattro™Post” must be loaded only axially; no load perpendicular to the column axis is allowed.
- “Quattro™Post” may be used vertically or under an angle as structural posts. Connection methods may include nails, screws, lag screws and brackets.
- “Quattro™Post” may only be notched with the permission of Synergy Pacific.
- “Quattro™Post” connector holes shall be pre-drilled.
- Through-bolting is not permitted on structural connections on “Quattro™Post.” Pilot holes are required for lag screws. The maximum permitted lag screw diameter is 12.7mm (½”).
- “Quattro™Post” holes shall be limited to 19mm (¾”) diameter. Holes are to be centered on the post and spaced vertically at least 203mm (8”) apart for multiple holes. Holes in addition to those required for installation of approved column caps and bases are not permitted within 203mm (8”) of the top or bottom of the post.
- “Quattro™Post” is to be stained or primed in accordance with the manufacturer’s instructions.
- “Quattro™Post” ends are factory-sealed to protect them from water damage. Trimmed material will require end sealing with an alkyl oil primer or equivalent.
- Non-load bearing “Quattro™Post” columns may be any size and length produced.

iii) Engineering Required

For structural applications beyond the scope/limitations of the above-referenced Synergy Pacific publication or when required by the AHJ, the drawings or related documents shall bear the authorized seal of a professional engineer skilled in wood design and licensed to practice under the appropriate provincial or territorial legislation.

“Quattro™Post” shall be designed in accordance with the requirements of CAN/CSA-O86-01 and Part 4 of Division B of the NBC 2005. The specified strengths and fastener limits for “Quattro™Post” shall not exceed the values set forth in Tables 4.1.1, 4.1.2, 4.1.3, 4.1.4 and 4.1.5.

The engineer shall design in accordance with CAN/CSA-O86-01, and may use as a guide, the “Engineering Guide for Wood Frame Construction,” published by the Canadian Wood Council.

iv) Engineering Support Provided by the Manufacturer

Synergy Pacific provides engineering support and may be consulted at:

www. quattropost.com
quattropost@ synergypacific.com

Tel.: (877) 546-6808
Fax: (250) 546-6815

The product must be identified with the following information:

- manufacturer’s name or logo; and
- the phrase “CCMC 13314-R.”

4. Technical Evidence

CCMC’s Technical Guide for “Glulam Fabricated with Profile Lamina” sets out the nature of the technical evidence required by CCMC to enable it to evaluate a product as an acceptable or alternative solution in compliance with the NBC 2005. The Report holder has submitted test results for CCMC’s evaluation. Testing was conducted at an independent laboratory recognized by CCMC. The corresponding test results for “Quattro™Post” are summarized below. There is one Table note that applies to all of the following Tables that is located after Table 4.1.5.

4.1 NBC 2005 Compliance Data for “Quattro™Post” on which CCMC Based its Opinion in Section 1

Table 4.1.1 Specified Strengths⁽¹⁾ and Stiffness for “Quattro™Post” – Spruce Pine Fir – Structural Select

Property (MPa)	Size (mm)		
	89	140	184
E	9 776	9 776	9 776
E ₀₅	8 505	8 505	8 505
fc @ 12% MC	20.51	18.80	17.91
fc @ 15% MC	17.55	16.09	15.32
fc @ 19% MC	13.63	12.49	11.90
fb @ 15% MC	17.46	16.01	15.25

Table 4.1.2. Specified Strengths⁽¹⁾ and Stiffness for “Quattro™Post” – Spruce Pine Fir – N2

Property (MPa)	Size (mm)		
	89	140	184
E	10 094	10 094	10 094
E ₀₅	8 782	8 782	8 782
fc @ 12% MC	19.13	17.53	16.70
fc @ 15% MC	16.40	15.04	14.32
fc @ 19% MC	12.80	11.73	11.17
fb @ 15% MC	15.24	13.97	13.30

Table 4.1.3. Specified Strengths⁽¹⁾ and Stiffness for “Quattro™Post” – Douglas Fir – Structural Select

Property (MPa)	Size (mm)		
	89	140	184
E	11 171	11 171	11 171
E ₀₅	9 719	9 719	9 719
fc @ 12% MC	23.01	21.10	20.09
fc @ 15% MC	19.69	18.05	17.19
fc @ 19% MC	15.34	14.06	13.40
fb @ 15% MC	18.69	17.14	16.32

Table 4.1.4. Specified Strengths⁽¹⁾ and Stiffness for “Quattro™Post” – Douglas Fir – N2

Property (MPa)	Size (mm)	Unit	Result
E	11 134	11 134	11 134
E ₀₅	9 687	9 687	9 687
fc @ 12% MC	20.80	19.07	18.17
fc @ 15% MC	17.81	16.33	15.55
fc @ 19% MC	13.87	12.71	12.11
fb @ 15% MC	16.43	15.06	14.35

Table 4.1.5. Specified Strengths⁽¹⁾ and Stiffness for “Quattro™Post” – Western Red Cedar – Structural Select

Property (MPa)	Size (mm)	Unit	Result
E	7 977	7 977	7 977
E ₀₅	6 940	6 940	6 940
fc @ 12% MC	15.62	14.31	13.63
fc @ 15% MC	13.35	12.23	11.65
fc @ 19% MC	10.39	9.52	9.07
fb @ 15% MC	17.42	15.97	15.21

Note to Tables 4.1.1 through 4.1.5:

(1) Specified strengths are for a standard term duration of load ($K_d = 1.0$). Specified strengths have been adjusted to a base volume of 0.515 m^3 (column $0.140 \text{ mm} \times 0.140 \text{ mm} \times 3.466 \text{ mm}$) where the volume factor is $K_{zc} = 1$. For other column volumes use the volume factor $K_{zc} = 0.68 * (z^{-0.13})$, but not greater than 1.3, where $z = \text{member volume (m}^3\text{)}$.

E – Modulus of Elasticity

fc – Modulus of Rupture

fb – Modulus of Rupture - bending

Report Holder: Synergy Pacific
 4175 Crozier Road
 Armstrong, BC
 V0E 1B6
 Tel. (877) 546-6808
 Fax: (250) 546-6815

Plant: Armstrong, BC

This Report is issued by the Canadian Construction Materials Centre, a program of the Institute for Research in Construction at the National Research Council of Canada. The Report must be read in the context of the entire CCMC Registry of Product Evaluations, including, without limitation, the introduction therein which sets out important information concerning the interpretation and use of CCMC Evaluation Reports.

Readers must confirm that the Report is current and has not been withdrawn or superseded by a later issue. Please refer to <http://irc.nrc.gc.ca/ccmc>, or contact the Canadian Construction Materials Centre, Institute for Research in Construction, National Research Council of Canada, 1200 Montreal Road, Ottawa, Ontario, K1A 0R6. Telephone (613) 993-6189. Fax (613) 952-0268.

NRC has evaluated the material, product, system or service described herein only for those characteristics stated herein. The information and opinions in this Report are directed to those who have the appropriate degree of experience to use and apply its contents. This Report is provided without representation, warranty, or guarantee of any kind, expressed, or implied, and the National Research Council of Canada (NRC) provides no endorsement for any evaluated material, product, system or service described herein. NRC accepts no responsibility whatsoever arising in any way from any and all use and reliance on the information contained in this Report. NRC is not undertaking to render professional or other services on behalf of any person or entity nor to perform any duty owed by any person or entity to another person or entity.